

Precipitation Monitor

Instruction for use

5.4103.1x.xxx; 5.4103.32.000



Dok. No. 021197/08/23

THE WORLD OF WEATHER DATA

Safety Instructions

- Before operating with or at the device/product, read through the operating instructions. This manual contains instructions which should be followed on mounting, start-up, and operation. A non-observance might cause:
 - failure of important functions
 - endangerment of persons by electrical or mechanical effect
 - damage to objects
- Mounting, electrical connection and wiring of the device/product must be carried out only by a qualified technician who is familiar with and observes the engineering regulations, provisions and standards applicable in each case.
- Repairs and maintenance may only be carried out by trained staff or **Adolf Thies GmbH & Co. KG**. Only components and spare parts supplied and/or recommended by **Adolf Thies GmbH & Co. KG** should be used for repairs.
- Electrical devices/products must be mounted and wired only in a voltage-free state.
- **Adolf Thies GmbH & Co KG** guarantees proper functioning of the device/products provided that no modifications have been made to the mechanics, electronics or software, and that the following points are observed:
- All information, warnings and instructions for use included in these operating instructions must be taken into account and observed as this is essential to ensure trouble-free operation and a safe condition of the measuring system / device / product.
- The device / product is designed for a specific application as described in these operating instructions.
- The device / product should be operated with the accessories and consumables supplied and/or recommended by **Adolf Thies GmbH & Co KG**.
- Recommendation: As it is possible that each measuring system / device / product may, under certain conditions, and in rare cases, may also output erroneous measuring values, it is recommended using redundant systems with plausibility checks for **security-relevant applications**.

Environment

- As a longstanding manufacturer of sensors Adolf Thies GmbH & Co KG is committed to the objectives of environmental protection and is therefore willing to take back all supplied products governed by the provisions of "ElektroG" (German Electrical and Electronic Equipment Act) and to perform environmentally compatible disposal and recycling. We are prepared to take back all Thies products concerned free of charge if returned to Thies by our customers carriage-paid.
- Make sure you retain packaging for storage or transport of products. Should packaging however no longer be required, please arrange for recycling as the packaging materials are designed to be recycled.



Documentation

- © Copyright **Adolf Thies GmbH & Co KG**, Göttingen / Germany
- Although these operating instruction has been drawn up with due care, **Adolf Thies GmbH & Co KG** can accept no liability whatsoever for any technical and typographical errors or omissions in this document that might remain.
- We can accept no liability whatsoever for any losses arising from the information contained in this document.
- Subject to modification in terms of content.
- The device / product should not be passed on without the/these operating instructions.

Inhaltsverzeichnis

1	Models Available.....	4
2	Application	4
3	Mode of Operation	5
3.1	Definition to the Precipitation Status / Relay Output.....	6
3.2	Definition to the Precipitation Event / Optocoupler Output	6
4	Installation.....	6
4.1	Mechanical Mounting.....	7
4.2	Electrical Mounting for Precipitation Sensor with Cable Gland.....	8
4.2.1	Connector for Precipitation Monitor with factory-connected Cable.....	8
4.2.2	Connector for Precipitation Monitor without factory-connected Cable.....	9
4.2.3	Electrical Mounting for Precipitation Sensor with Plug Connection	9
4.2.4	Connection Diagramm	10
5	Taking Into Operation	12
6	Maintenance	12
7	Settings.....	13
7.1	Setting of Incidences and Switch-off Delay	13
7.2	DIP-Switch Setting: 5.4103.10.000 / 700, 5.4103.11. 000, 5.4103.10. 112	14
7.3	DIP-Switch Setting: 5.4103.32.000	14
7.4	Setting of the Heating Mode	15
8	Technical Data.....	15
9	Dimension Drawing.....	16
10	Accessories (Optional).....	18
11	EC-Declaration of Conformity	19
12	UK-CA-Declaration of Conformity	20

1 Models Available

Article - Nr.	Measuring value	Electrical Output	Operating Voltage	Heating	Equipment / Connection
5.4103.10.000	Precipitation status	-Relay -Optocouplers	12 ... 28V AC/DC	yes mode A	Terminal strip and cable gland.
5.4103.10.700	Precipitation status	-Relay -Optocouplers	12 ... 28V AC/DC	yes mode A	7 pole plug connection.
5.4103.10.112	Precipitation status	-Relay -Optocouplers	12 ... 28V AC/DC	yes mode C	-Terminal strip and cable gland. - Function and terminal strip for external ON/OFF-heating control.
5.4103.11.000	Precipitation status	-Relay -Optocouplers	12 ... 28V AC/DC	yes mode A	Terminal strip and cable gland.
5.4103.32.000	Precipitation status	-Relay -Optocouplers	12 ... 28V AC/DC	yes mode B	1.55m cable, firmly connected, cable end is open and marked.

2 Application

The precipitation monitor transmits signals to determine the beginning and the end of precipitation and the duration of the period of precipitation as required by meteorological services.

In addition, the precipitation monitor can be used to report status or to transmit control signals to connected rain protection devices such as windows, air vents, awnings, or venetian blinds.

The output of the precipitation status / event occurs galvanically isolated via:

- A relay with changeover contacts and normally closed contacts.
- An optocoupler.

3 Mode of Operation

Precipitations in the form of drizzle, rain, snow, or hail are acquired by a light barrier system, and trigger a switch signal.

An integrated event filter suppresses the triggering of the switch signal with accidental single events, such as leaves, bird droppings, insects etc.

Output 1: (relay)

The relay signalizes the start and end of a precipitation period.

Start of Precipitation:

The recorded events (raindrops, hailstones, etc.) are compared with the set threshold value (number of events) within a time frame of 50sec. On reaching the threshold value the relay is switched.

The time frame is to be considered as gliding, i.e. you always look into the past. When after the start of a precipitation event the number of events for the threshold value is reached within a short time (< 50sec.) the relay is switched. This might occur even within a clearly shorter time than 50sec.

End of Precipitation:

The reset of the relay, i.e. the end of the precipitation period, occurs when no more raindrops, hail stones, etc. are detected after a defined delay.

Output 2: (optocoupler)

The optocoupler signalizes each event, as soon as a particle has been acquired by the light barrier. The acquisition or signalizing is carried out without filtering and without delay.

Heating

The instrument is equipped with a heating system for extreme weather condition. This avoids ice and snow forming on the housing surface. In addition, the surface retains a temperature of >0° by means of a regulated heating.

Heating mode for:

Different modes of heating are possible:

Heating mode A

The heating is always active, the control temperature is at approx. 8°C.

Heating mode B

The heating is active, when the precipitation monitor detected precipitation, and the ambient temperature is at < 8°C.

Heating mode C

The heating can be switched ON or OFF externally, control temperature is at approx. 8°C.

Heating mode D

The heating can be switched ON or OFF externally, and is active when the precipitation monitor detected precipitation, and the ambient temperature is at < 8°C.

Housing

The housing consists of polycarbonate, the support of stainless steel. A special coating serves for reducing measurement errors which might arise by drop formation at the housing in the range of the measured distance. This coating must not be removed.

3.1 Definition to the Precipitation Status / Relay Output

Precipitation „yes“	= Relay contact W + R closed
Precipitation „no“	= Relay contact W + A closed
Power failure (sensor „off“)	= Relay contact W + R closed

- Precipitation „yes“ is signalized with missing or interrupted operating voltage (sensor „off“); thus device protection is existing even in this status.

3.2 Definition to the Precipitation Event / Optocoupler Output

Precipitation „yes“	= Optocoupler C + E closed, pulse duration 60msec
Precipitation „no“	= Optocoupler C + E open
Stromausfall (Sensor „aus“)	= Optocoupler C + E open

- With missing or interrupted operating voltage (sensor „off“) there is no particle precipitation signalized.

4 Installation

Please Note:

The hydrophilic coating must not be damaged. The electrical connection is to be carried out by experts only. Please open the instrument only with dry ambient conditions. Do not damage the exposed electronics!

Remark:

In order to achieve an optimal electro-magnetic immunity (> 20V/m) please use shielded cable.

4.1 Mechanical Mounting

Note:

When mounting and aligning, take into account that direct sunlight on the receiving diodes can cause the sensor to malfunction.

When using several precipitation sensors in parallel operation, the distance between the mast must be greater than 1.5m.

When using sensors of other manufacturers with infrared measuring technology, it must be excluded that the receiving diodes of the precipitation sensor are disturbed. This can be realized e.g. by appropriate alignment of the sensors.

receiving diodes

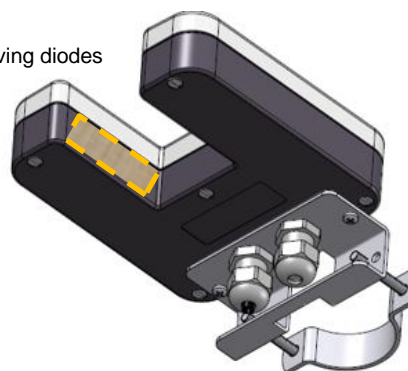

5.4103.10.xxx, 5.4103.30x.xxx

The operating position of the precipitation monitor is horizontal.

The mounting system of the instrument is designed for attachment to a mast. When mounting make sure, that the precipitation can easily reach the sensor field, and that the instrument, while operating, is not exposed to strong vibrations or shocks.

The pictured tube is not included in delivery.

Area of the coating

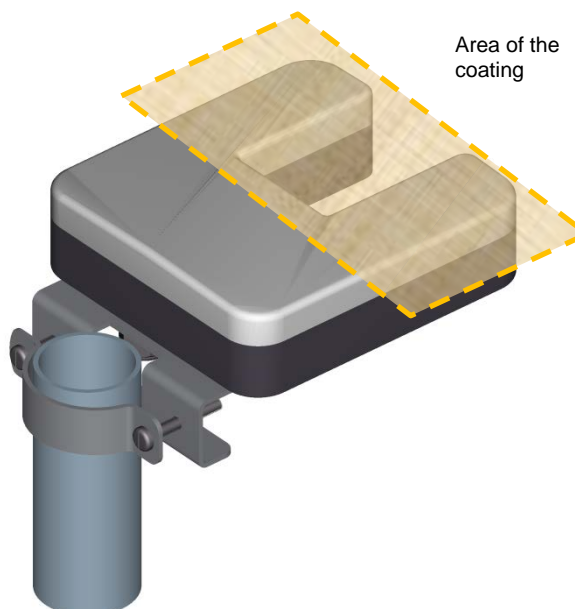

5.4103.11.000

The operating position of the precipitation monitor is horizontal.

The holding angle of the instrument is used for the mounting at a vertical surface. When mounting make sure, that the precipitation can easily reach of the sensor hole, and that the instrument, while operating, is not exposed to strong vibrations or shocks.

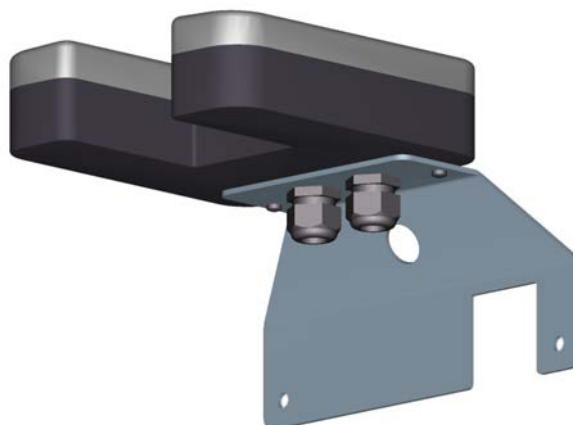

4.2 Electrical Mounting for Precipitation Sensor with Cable Gland

4.2.1 Connector for Precipitation Monitor with factory-connected Cable

For: 5.4103.32.000, see circuit diagram in chapter 4.

4.2.2 Connector for Precipitation Monitor without factory-connected Cable

For: 5.4103.10.000, 5.4103.11.000, 5.4103.10.112, see circuit diagram in chapter 4.

Process:

- Remove 5 screws at the bottom side of the precipitation monitor.
- Remove upper part (cover). The connecting terminals are the freely accessible.
- Insert a respective prepared cable from the bottom through the cable glands situated in the housing bottom, and connect it to the connecting terminals and shield connector, acc. to circuit diagram.
- Secure cable by cable glands.
- Put on the upper part again and screw it evenly and tightly to the bottom.

Attention:

Make sure, that the contact pins are not deformed when putting on the cover.

The fixing screws for the cover must be screwed down with a torsional of **1Nm to 2Nm**.

4.2.3 Electrical Mounting for Precipitation Sensor with Plug Connection

For: 5.4103.10.700, see circuit diagram in chapter 4.

4.2.3.1 Plug Mounting

Applies only to instruments with connection „plug“.

Coupling socket, type: Binder, Serial 423, EMC with cable clamp

Cable connection: without cable shield

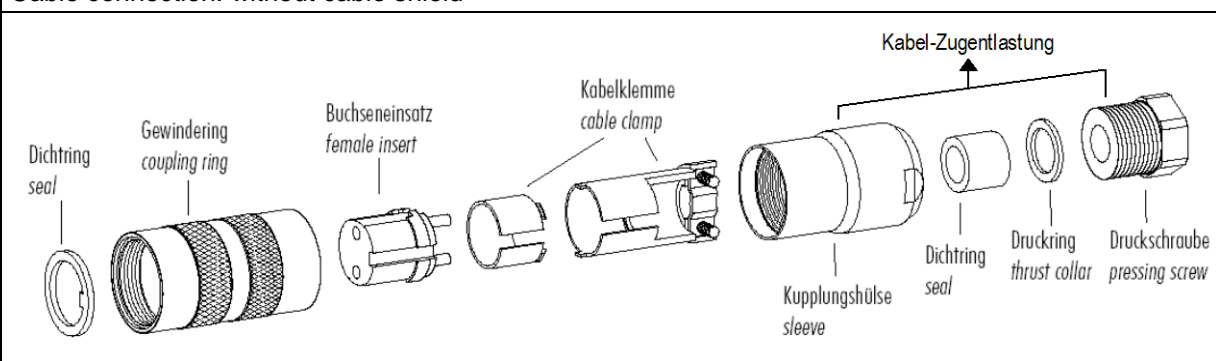

1. Stringing parts on cable acc. to plan given above.
2. Stripping cable sheath 20mm.
3. Cutting uncovered shield 20mm.
4. Stripping wire 5mm.
5. Soldering wire to the insert.
6. Positioning shield in cable clamp.
7. Screwing-on cable clamp.
8. Assembling remaining parts acc. to upper plan.
9. Tightening pull-relief of cable by screw-wrench (SW16 und 17).

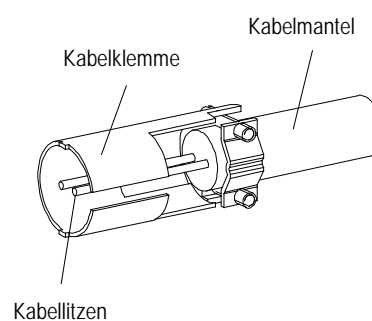

4.2.4 Connection Diagramm

Note:

The cable shield must only be placed on the side of the power supply.

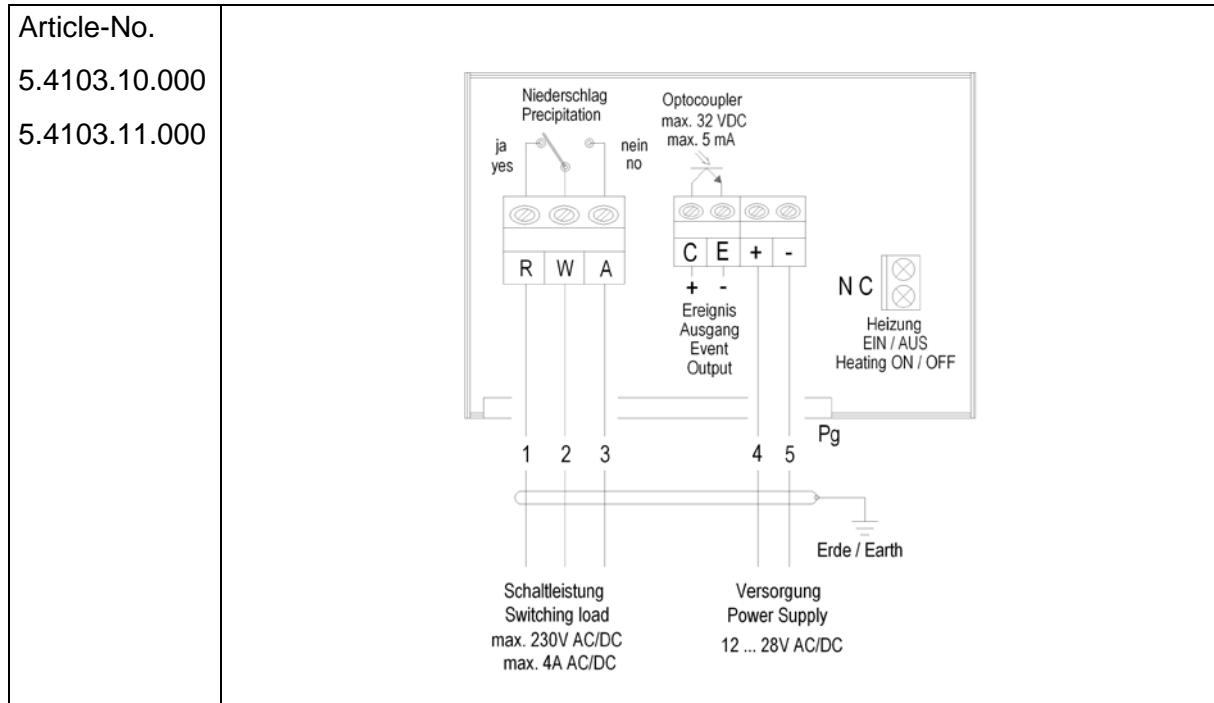

Article-No.
5.4103.10.700

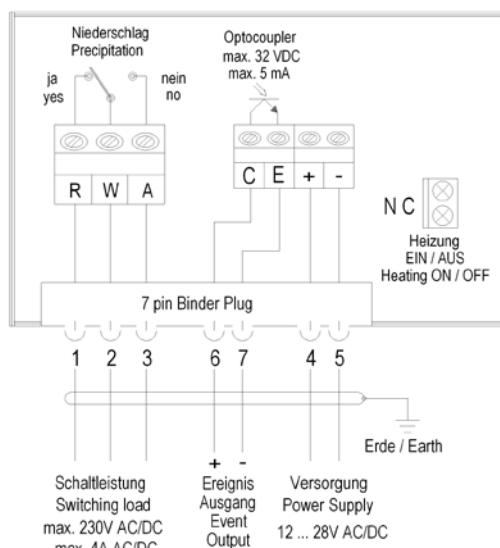

Polbild mit Sicht auf
Lötanschluss des
Gegenstecker

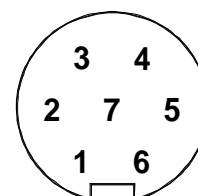

Article-No.
5.4103.10.112

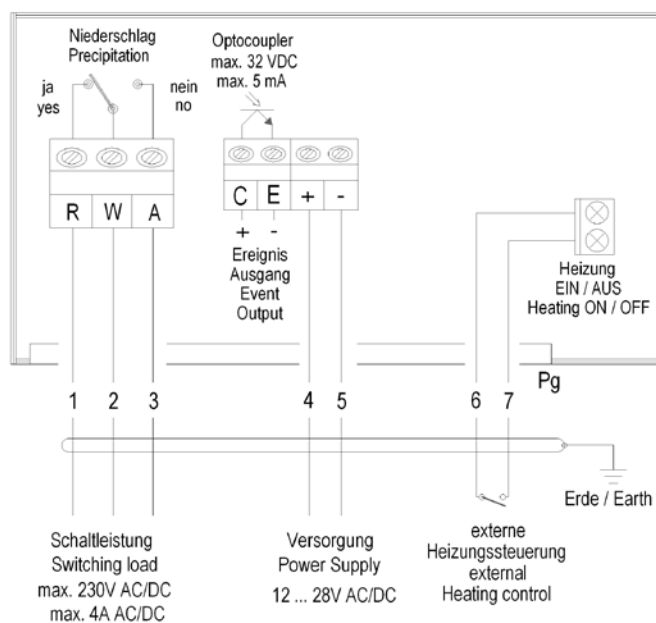

Heating ON /OFF:

- Heating ON = the contact is closed.
- Heating OFF = the contact is open.

Article-No.
5.4103.32.000

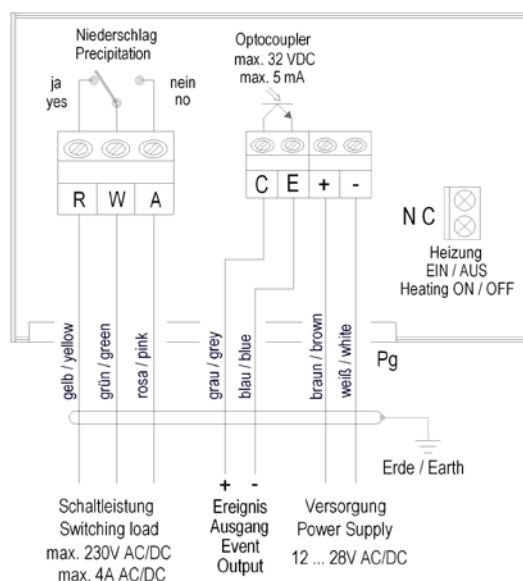

Figure: Instrument with connected cable.
Cable type: 7 x 0,25LIYCY, UV- resistant, Ø 6mm.
Figure status: instrument power-off or precipitation „yes“.

5 Taking Into Operation

After the electrical connection has been established, and the case has been screwed, the operating voltage can be switched on. The setting of the relay output is undefined after switching on the operating voltage and shows „no precipitation“.

6 Maintenance

The device is maintenance free.

Cleaning:

The pollution and the pollution level is dependent on the location. Therefore, we recommend the unit be checked at appropriate intervals and cleaned if necessary.

For the cleaning should use a damp cloth without chemical cleaning agents are used.

Remark:

The housing is coated in the front section and in the sensor area. This coating must not be damaged.

We recommend to clean (rinse) the instrument only with water, and to blot it with a soft cloth, if necessary. Please take care that no water gets into the instrument. Excessive rubbing might remove the coating.

We recommend the threads of the plugs with a suitable corrosion inhibitors to protect against corrosion.

Remark:

Events can, possibly, be activated with the cleaning work; they should be considered then with the evaluation / further processing.

7 Settings

7.1 Setting of Incidences and Switch-off Delay

The criteria of signal output for start and end of the precipitation are factory-set.

If the factory-setting has to be changed due to special ambient conditions this can be done by means of switches **DIP1** and **DIP2**.

DIP1 = Switch-off delay (for the end of precipitation period).

DIP2 = Drop event filter (for the start of precipitation period).

Settings see **table 1 or 2**

Process:

- Interrupt power supply and signal current.
- Remove 5 screws at the bottom side of the instrument.
- Remove upper part (cover).
- Set switch DIP1 / DIP2 acc. to table 1 or 2.
- Put on the upper part again and screw it evenly and tightly to the bottom.

Attention:

The screws for the cover must be tightened by a torque of **1Nm to 2Nm**.

Make sure, that the contact pins are not deformed when putting on the cover.

- Restart instrument.

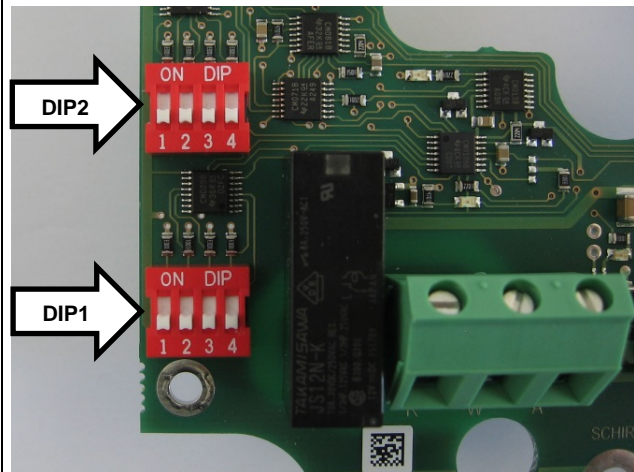

Figure 1: Position of DIP – switch

7.2 DIP-Switch Setting: 5.4103.10.000 / 700, 5.4103.11. 000, 5.4103.10. 112

DIP1- switch Function: off delay					DIP2- switch Function: drop incidences-filter				
S 1	S 2	S 3	S 4	Time (sec)	S 1	S 2	S 3	S 4	Drops
ON	OFF	OFF	OFF	25	ON	OFF	OFF	OFF	1
OFF	ON	OFF	OFF	50	OFF	ON	OFF	OFF	2
ON	ON	OFF	OFF	75	ON	ON	OFF	OFF	3
OFF	OFF	ON	OFF	100	OFF	OFF	ON	OFF	4
ON	OFF	ON	OFF	125	ON	OFF	ON	OFF	5
OFF	ON	ON	OFF	150	OFF	ON	ON	OFF	6
ON	ON	ON	OFF	175	ON	ON	ON	OFF	7
OFF	OFF	OFF	ON	200	OFF	OFF	OFF	ON	8
ON	OFF	OFF	ON	225	ON	OFF	OFF	ON	9
OFF	ON	OFF	ON	250	OFF	ON	OFF	ON	10
ON	ON	OFF	ON	275	ON	ON	OFF	ON	11
OFF	OFF	ON	ON	300	OFF	OFF	ON	ON	12
ON	OFF	ON	ON	325	ON	OFF	ON	ON	13
OFF	ON	ON	ON	350	OFF	ON	ON	ON	14
ON	ON	ON	ON	375	ON	ON	ON	ON	15

- Grey marked squares = factory settings.
- DIP – switch adjustment „OFF, OFF, OFF, OFF“: not defined.

7.3 DIP-Switch Setting: 5.4103.32.000

DIP1- switch Function: off delay					DIP2- switch Function: drop incidences-filter				
S 1	S 2	S 3	S 4	Time (sec)	S 1	S 2	S 3	S 4	Drops
ON	OFF	OFF	OFF	12,5	ON	OFF	OFF	OFF	1
OFF	ON	OFF	OFF	25	OFF	ON	OFF	OFF	2
ON	ON	OFF	OFF	37,5	ON	ON	OFF	OFF	3
OFF	OFF	ON	OFF	50	OFF	OFF	ON	OFF	4
ON	OFF	ON	OFF	62,5	ON	OFF	ON	OFF	5
OFF	ON	ON	OFF	75	OFF	ON	ON	OFF	6
ON	ON	ON	OFF	87,5	ON	ON	ON	OFF	7
OFF	OFF	OFF	ON	100	OFF	OFF	OFF	ON	8
ON	OFF	OFF	ON	112,5	ON	OFF	OFF	ON	9
OFF	ON	OFF	ON	125	OFF	ON	OFF	ON	10
ON	ON	OFF	ON	137,5	ON	ON	OFF	ON	11
OFF	OFF	ON	ON	150	OFF	OFF	ON	ON	12
ON	OFF	ON	ON	162,5	ON	OFF	ON	ON	13
OFF	ON	ON	ON	175	OFF	ON	ON	ON	14
ON	ON	ON	ON	187,5	ON	ON	ON	ON	15

- Grey marked squares = factory settings.
- DIP – switch adjustment „OFF, OFF, OFF, OFF“: not defined.

7.4 Setting of the Heating Mode

Heating mode is factory-set.

If the factory-setting has to be changed due to special ambient conditions this can be done by means of solder bridges. This procedure should be carried out by the manufacturer.

8 Technical Data

Measuring values	<ul style="list-style-type: none"> Precipitation status „yes / no“ via relay Particle event as pulse via optocoupler
Measuring system / Sensor	Optical, light-barrier.
Sensor area	: 25cm ²
Drop size	: ≥ 0,2mm
Output 1	
Switch output relay	Precipitation „yes“ = relay-contract W + R closed Precipitation „no“ = relay-contract W + A closed Power failure (Sensor „off“) = relay-contract W + R closed
Switch-on condition	1... 15 incidences within 50sec. (settable)
Switch-off delay 5.4103.10.xxx 5.4103.32.000	25 ... 375sec 2,5...187.5sec See „Adjusting incidences and switch-off delay“
Output 2	
Signal output optocoupler Output rate	Precipitation particles trigger signal pulse Max. 15pulse/s
Switch-on condition	1 event
Switch-off delay	None
General	
Specification relay Contact loading (relay) Attention: with model 5.4103.10.700	230V AC; 4A Max. 60V AC; 4A
Specification optocoupler Output Pulse output Pulse duration	Photo transistor, galvanically isolated, C=+ Pot., E=- Pot U _{max.} = 32V I _{max.} = 5mA 60msec
Operating voltage	12V ... 28V AC/DC
Operation current	Ca. 50mA @ no precipitation, heating off Ca. 30mA @ precipitation, heating off

Heating Control temperature Hysteresis Power	Two-level-controller approx. 8°C 0,1K Max. 0,5A @ 12V, max. 1A @ 25V
Ambient temperature	-30 ... +60°C
Protection	IP 65 acc. to DIN 40050
Weight	0.4kg
Connection	See model

9 Dimension Drawing

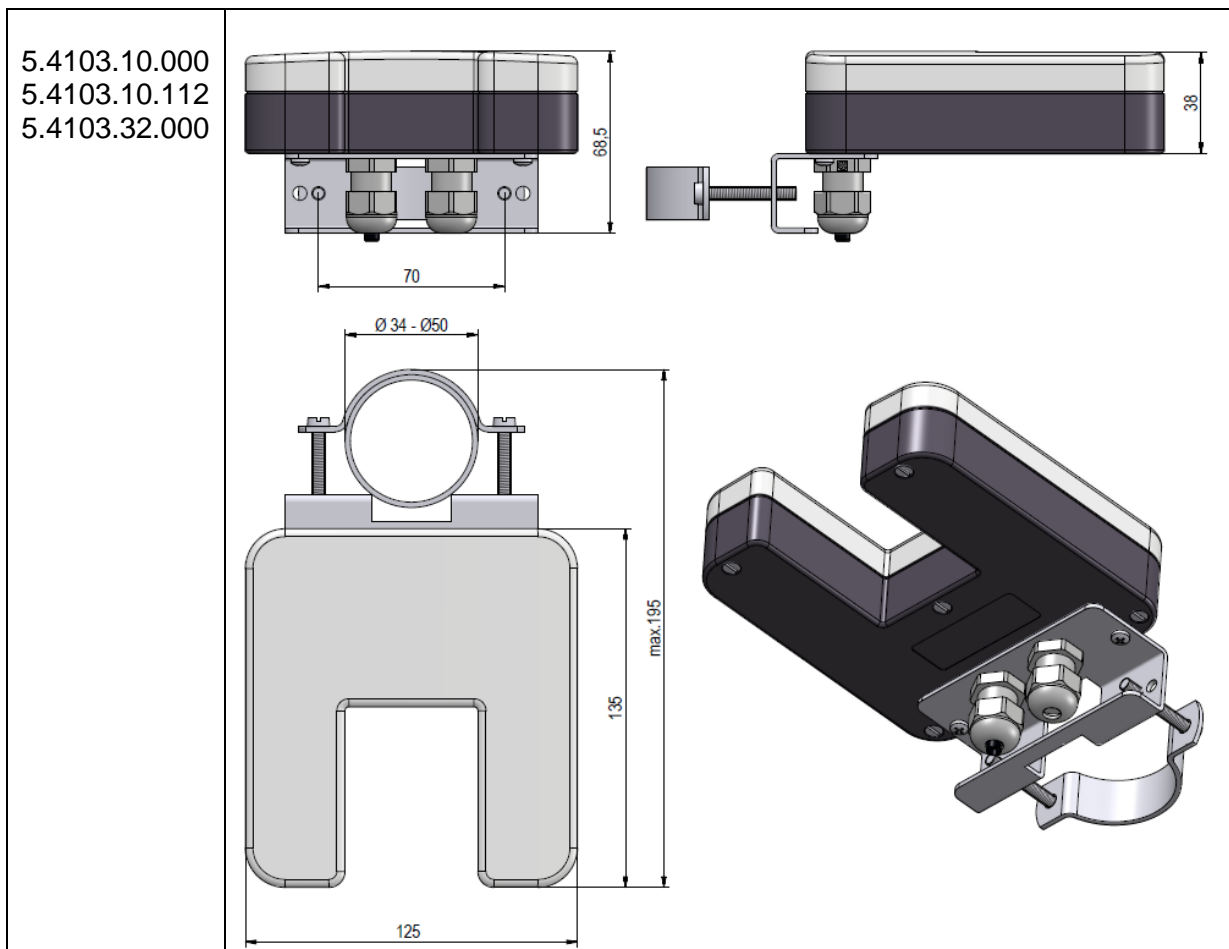

5.4103.10.700

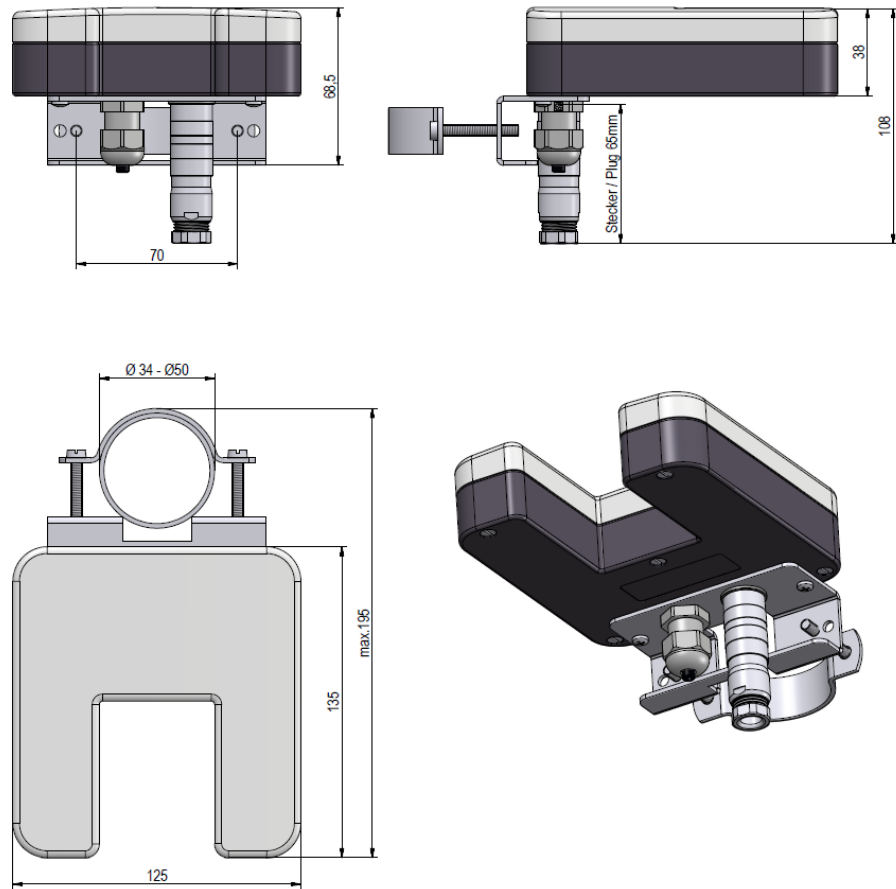

5.4103.11.000

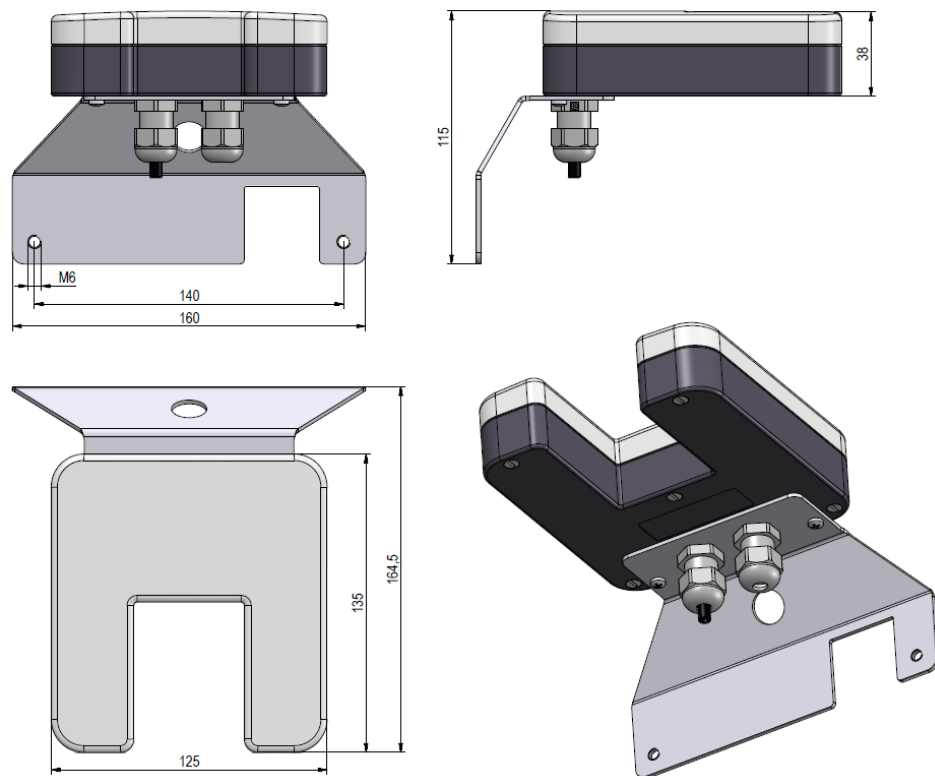

10 Accessories (Optional)

Power Supply Unit	9.3388.00.002	<p>The power supply unit serves for the current supply of the precipitation monitor, order-no. 5.4103.10.000. It supplies the necessary operation voltage for the electronics and the heating.</p> <p>Primary : 230V / 50Hz Secondary : 24V AC / 25VA Housing : synthetic Protection : IP 65 acc. with DIN 40050 Dimensions : 107 x 125 x 100mm Weight : 1,2kg</p>
-------------------	---------------	---

11 EC-Declaration of Conformity

Manufacturer: Adolf Thies GmbH & Co. KG
 Hauptstraße 76
 37083 Göttingen, Germany
<http://www.thiesclima.com>

Product: Precipitation Transmitter

Doc. Nr. 902-44544_CE

Article Overview:

5.4103.10.000 5.4103.10.012 5.4103.10.112 5.4103.10.700 5.4103.11.000 5.4103.20.041 5.4103.20.741 5.4103.21.021 5.4103.30.000 5.4103.30.700
 5.4103.31.000 5.4103.32.000

The indicated products correspond to the essential requirement of the following European Directives and Regulations:

2014/30/EU	26.02.2014	DIRECTIVE 2014/30/EU OF THE EUROPEAN PARLIAMENT AND OF THE COUNCIL of 26 February 2014 on the harmonisation of the laws of the Member States relating to electromagnetic compatibility.
2014/35/EU	26.02.2014	DIRECTIVE 2014/35/EU OF THE EUROPEAN PARLIAMENT AND OF THE COUNCIL of 26 February 2014 on the harmonisation of the laws of the Member States relating to the making available on the market of electrical equipment designed for use within certain voltage limits.
2017/2102/EU	15.11.2017	DIRECTIVE (EU) 2017/2102 of the European Parliament and of the Council of November 15, 2017 amending Directive 2011/65 / EU on the restriction of the use of certain hazardous substances in electrical and electronic equipment.
2012/19/EU	13.08.2012	DIRECTIVE 2012/19/EU OF THE EUROPEAN PARLIAMENT AND OF THE COUNCIL of 4 July 2012 on waste electrical and electronic equipment (WEEE).
2018/1139/EU	04.07.2018	Regulation (EU) 2018/1139 of the European Parliament and of the Council of 4 July 2018 on common rules in the field of civil aviation and establishing a European Union Aviation Safety Agency.

The indicated products comply with the regulations of the directives. This is proved by the compliance with the following standards:

DIN EN 61000-6-2	2019-11	Electromagnetic compatibility Immunity for industrial environment
DIN EN 61000-6-3	2012-11	Electromagnetic compatibility (EMC). Generic standards. Emission standard for residential, commercial and light-industrial environments
DIN EN 61010-1	2020-03	Safety requirements for electrical equipment for measurement, control, and laboratory use. General requirements
DIN EN 63000	2019-05	Technical documentation for the assessment of electrical and electronic products with respect to the restriction of hazardous substances.

This declaration of conformity is issued under the sole responsibility of the manufacturer.

Legally binding signature:



General Manager - Dr. Christoph Peper

Legally binding signature:



Development Manager - ppa. Jörg Petereit

This declaration certifies the compliance with the mentioned directives, however does not include any warranty of characteristics.
 Please pay attention to the security advises of the provided instructions for use.

12 UK-CA-Declaration of Conformity

Manufacturer: Adolf Thies GmbH & Co. KG
 Hauptstraße 76
 37083 Göttingen, Germany
<http://www.thiesclima.com>

Product: Precipitation Transmitter

Doc. Nr. 902-44544_CA

Article Overview:

5.4103.10.000 5.4103.10.012 5.4103.10.112 5.4103.10.700 5.4103.11.000 5.4103.20.041 5.4103.20.741 5.4103.21.021 5.4103.30.000 5.4103.30.700
 5.4103.31.000 5.4103.32.000

The indicated products correspond to the essential requirement of the following European Directives and Regulations:

1091	08.12.2016	The Electromagnetic Compatibility Regulations 2016
1101	08.12.2016	The Electrical Equipment (Safety) Regulations 2016
RoHS Regulations 2	01.01.2021	The Restriction of the Use of Certain Hazardous Substances in Electrical and Electronic Equipment Regulations 2012
3113	01.01.2021	Regulations: waste electrical and electronic equipment (WEEE)
2018/1139/EU	04.07.2018	Regulation (EU) 2018/1139 of the European Parliament and of the Council of 4 July 2018 on common rules in the field of civil aviation and establishing a European Union Aviation Safety Agency.

The indicated products comply with the regulations of the directives. This is proved by the compliance with the following standards:

BS EN IEC 61000-6-2	25.02.2019	Electromagnetic compatibility (EMC). Generic standards. Immunity standard for industrial environments
BS EN IEC 61000-6-3	30.03.2021	Electromagnetic compatibility (EMC). Generic standards. Emission standard for equipment in residential environments
BS EN 61010-1+A1	31.03.2017	Safety requirements for electrical equipment for measurement, control, and laboratory use. General requirements
BS EN IEC 63000	10.12.2018	Technical documentation for the assessment of electrical and electronic products with respect to the restriction of hazardous substances

This declaration of conformity is issued under the sole responsibility of the manufacturer.

Legally binding signature:



General Manager - Dr. Christoph Peper

Legally binding signature:



Development Manager - ppa. Jörg Petereit

This declaration certifies the compliance with the mentioned directives, however does not include any warranty of characteristics.
 Please pay attention to the security advises of the provided instructions for use.

ekotechnika
měřicí technika pro ekologii

Ing. Milan Kříž - Ekotechnika
Kloboučnická 20, 140 00 Praha 4

 +420 241 414 111

 info@ekotechnika.com

 www.ekotechnika.com

**Please contact us for your system requirements.
We advise you gladly.**

ADOLF THIES GMBH & CO. KG

Meteorology and environmental metrology

Hauptstraße 76 · 37083 Göttingen · Germany

Phone +49 551 79001-0 · Fax +49 551 79001-65

info@thiesclima.com



www.thiesclima.com